

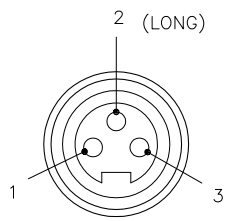

MALE END VIEW (P1)	FEMALE END VIEW (J1)	WIRING DIAGRAM	SPECIFICATIONS	
			CONTACT CARRIER MATERIAL/COLOR	PVC/BLACK (P1), TPU/BLACK (J1)
			MOLDED HEAD MATERIAL/COLOR	PVC/BLACK
			CONTACT MATERIAL/PLATING	BRASS or COPPER/GOLD
			COUPLING NUT MATERIAL/PLATING	BRASS/NICKEL
			RATED CURRENT [A]	15 A
			RATED VOLTAGE [V]	600 V
			TEMPERATURE RANGE	-40°C to +90°C (-40°F to +194°F)
	 M16 connector			

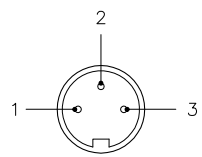
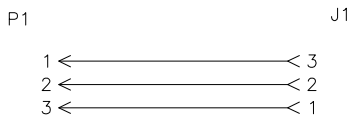

SOURCE DRAWING - FOR REFERENCE ONLY

CAUTION:
RISK OF ELECTRICAL SHOCK
DO NOT DISCONNECT UNDER LOAD

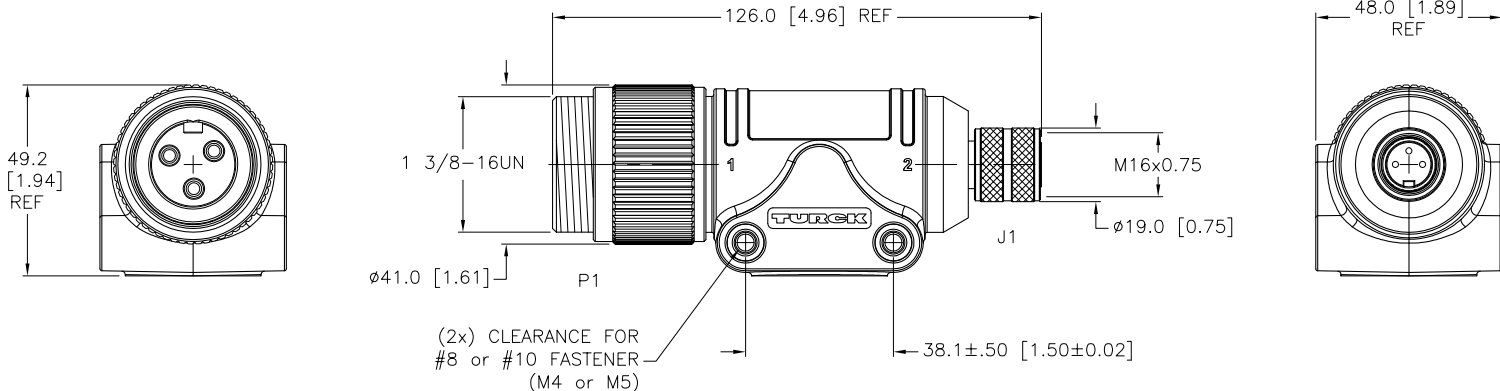
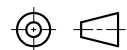
RELATED DOCUMENTS 1. 2. 3. 4.	3RD ANGLE PROJECTION 	THIS DRAWING IS PROPERTY OF TURCK INC. USE OF THIS DOCUMENT WITHOUT WRITTEN PERMISSION IS PROHIBITED.	<div style="display: flex; justify-content: space-between;"> <div data-bbox="1470 1307 1848 1372"> TURCK INC <i>High Technology Sensors and Automation Controls</i> </div> <div data-bbox="1858 1282 2058 1396"> 3000 CAMPUS DRIVE MINNEAPOLIS, MN 55441 1-800-544-7769 (763) 553-7300 (763) 553-0708 fax turck.com </div> </div>		
MATERIAL SEE SPECIFICATIONS	ALL DIMENSIONS DISPLAYED ON THIS DRAWING ARE FOR REFERENCE ONLY	DRFT RWC	DATE 07/17/09	DESCRIPTION GSDM BKM 34-0	
FINISH SEE SPECIFICATIONS	CONTACT TURCK FOR MORE INFORMATION	DSGN	SCALE 1=2.0	IDENTIFICATION NO. U2-14803	
		UNIT OF MEASUREMENT MILLIMETER [INCH]		REV C	
		DO NOT SCALE THIS DRAWING		FILE: U2-14803	SHEET 1 OF 1

C	DRAWING PROCESSED AS PART OF ECO 33971	CBM	04/07/11	33971
REV	DESCRIPTION	BY	DATE	ECO NO.